

Sunbeam

HANDVAC

Model SBH-200



In a continuous effort to improve our products, we reserve the right to change components and materials without notice.

CAUTION

**PLEASE READ AND FOLLOW ALL SAFETY
RULES AND OPERATING INSTRUCTIONS**

Important Safety Instructions

⚡WARNING⚡

To reduce the risk of fire, electrical shock, or injury when using your vacuum cleaner, follow these basic precautions:

- Read all instructions before using the vacuum.
- Do not plug into electrical supply until assembly is complete. Failure to do so could result in electrical shock or injury.
- Electric shock could occur if used outdoors or on wet surfaces.
- Never leave a vacuum cleaner plugged in and unattended near children.
- Keep children away from the vacuum cleaner at all times. Injury could result from suction.
- Never vacuum cigarette butts or fireplace ashes.
- Never use vacuum cleaner where flammable vapors from cleaning fluids, perfumes, etc. are present. This could start a fire.
- Do not use outlets above counters. Damage to items in surrounding areas could occur.
- Never operate with a damaged cord or plug.
- Always turn off cleaner before removing or replacing any parts from the vacuum cleaner.
- Always change the dust bag after vacuuming carpet cleaners or fresheners, powders and fine dust. These products clog the bag, reduce airflow and can cause the bag to burst. Do not block any opening.
- Always turn off the vacuum cleaner before unplugging it.
- Always unplug the power cord by pulling the plug, not the cord.
- Always unplug your vacuum cleaner whenever you leave it for more than a moment or when not in use.
- Use only recommended parts and attachments.
- Unit should always be connected to properly grounded outlet only.
- Do not use without a dust bag.
- Do not handle plug or appliances with wet hands.

-SAVE THESE INSTRUCTIONS-

TABLE of CONTENTS

Important Safety Instructions _____	2
Exploded View for Model SBH-200 _____	4
Assembling Your Vacuum _____	5
Operating Instructions _____	6
Changing and Cleaning the Dust Cup Filter _____	6
Troubleshooting Guide _____	7
Service for your Vacuum _____	7
Warranty Information _____	8



Sunbeam genuine parts and service: 1-866-933-0427

CAUTION

The suction hole (1) must be open and free of obstructions at all times. Otherwise, the motor will overheat and could get damaged.

EXPLODED VIEW

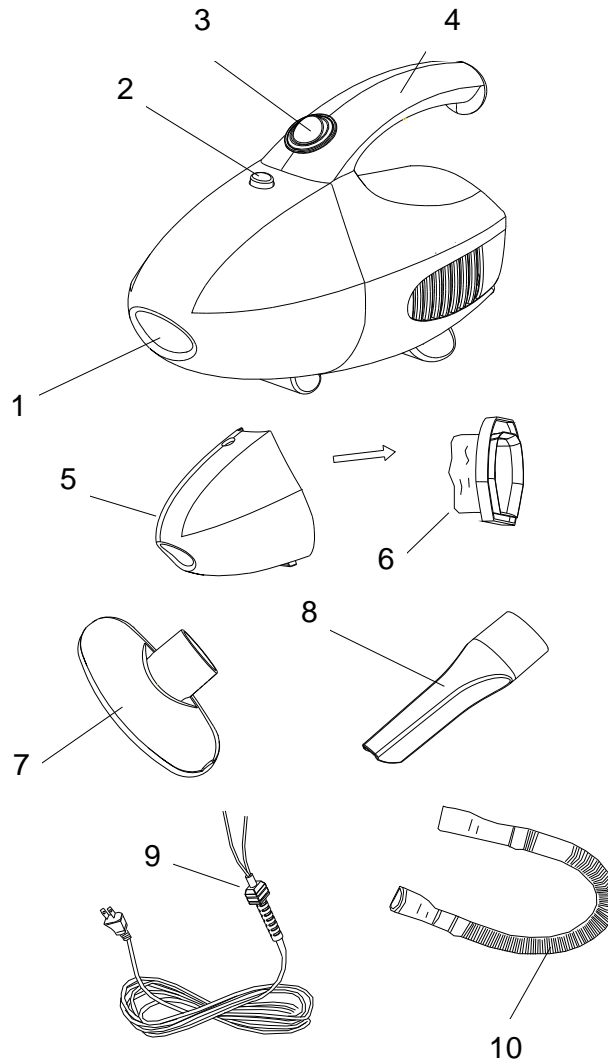

- 1. Suction Hole
- 2. Dust Cup Release Button
- 3. Power Switch
- 4. Handle
- 5. Dust Cup Container

- 6. Dust Cup Filter
- 7. Furniture Brush
- 8. Crevice Tool
- 9. Power Cord
- 10. Extension Hose

⚡WARNING⚡

Improper use of the power cord can result in the risk of electrical shock. If the power cord is damaged, have it replaced by an authorized service center.

ASSEMBLING YOUR VACUUM

Check all the parts and identify them against the illustration.

➤ ASSEMBLING YOUR VACUUM CLEANER

Warning: Always unplug from electrical outlet before opening the Dust Cup (5).

Note: Dust Cup Filter (6) must be used when operating the handvac.

1. To open the Dust Cup (5), push Dust Cup Release Button (5) and pull out the Dust Cup (5).
Verify that the Dust Cup Filter (6) is inside then attach the Dust Cup (5) to the handvac.

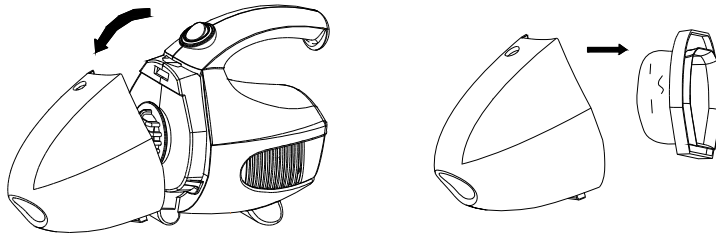

2. To attach the Furniture Brush (7) or Crevice Tool (8) to the handvac, push brush into the Suction Hole (1), as shown below.

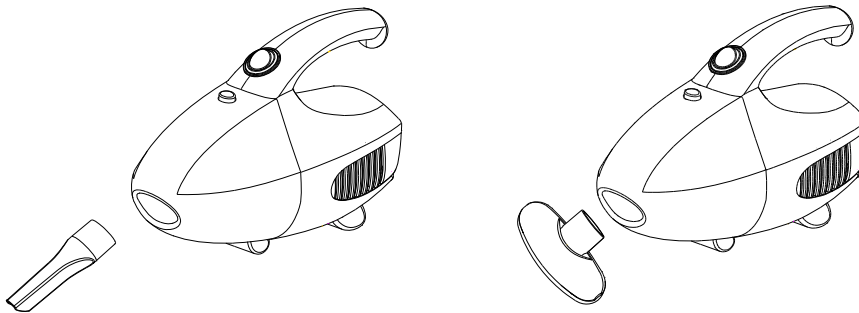

3. To use the Extension Hose (10), push the end of the hose into the Suction Hole (1) to use independently, or you may attach the desired brush (7 or 8) to the other end of the Extension Hose (10), as shown below.

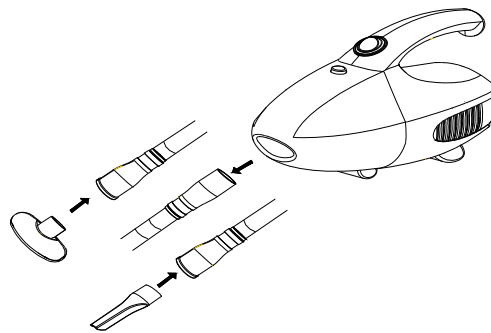

OPERATING INSTRUCTIONS

➤ TO OPERATE

Hold the handvac firmly with your hand on the Handle (4).

➤ TURNING VACUUM ON

Push the I/O Power Switch (3) to "I" position.

<u>CAUTION</u>	The Hand Vacuum is a very powerful machine. Make sure that you hold it firmly; otherwise it can slip out of your grasp and cause injury.
-----------------------	---

CHANGING & CLEANING THE DUST CUP FILTER

Warning: Always unplug from electrical outlet before opening the Dust Cup (5).

Reminder: It is better to wash the filter after using handvac.

1. To open the Dust Cup (5), push Dust Cup Release Button (2) and pull out the Dust Cup (5) (fig. 1).
2. Pull out the Dust Cup Filter (6) (fig. 2).
3. Empty the dust from the Dust Cup Filter (6).
4. Rinse the Dust Cup Filter (6) in cold water, and then wait until it completely dries before replacing it into the Dust Cup (5) (fig. 3).
5. Place the Dust Cup Filter (6) carefully into the Dust Cup (5) (fig. 4).
6. Attach the Dust Cup (5) to the handvac.

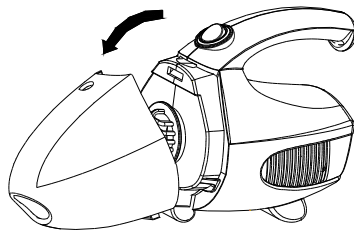

fig.1

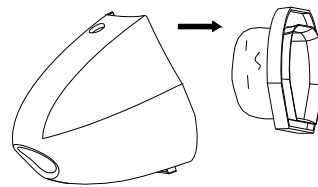

fig.2



fig.3

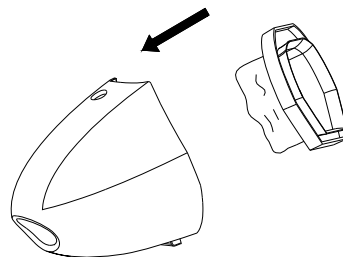

fig.4

TROUBLESHOOTING GUIDE

PROBLEM	POSSIBLE REASON	POSSIBLE SOLUTION
HAND VACUUM WILL NOT OPERATE	<ol style="list-style-type: none"> 1. Power Cord not firmly plugged into outlet. 2. No power in wall outlet. 	<ol style="list-style-type: none"> 1. Plug unit in firmly. 2. Check fuse or breaker. 3. Replace fuse/reset breaker. 4. Take it to the authorized dealer.
HAND VACUUM WILL NOT PICK-UP OR SUCTION POWER IS WEAK	<ol style="list-style-type: none"> 1. Dust Cup Filter is full. 2. Unit clogged. 3. Dust Cup Filter needs cleaning. 	<ol style="list-style-type: none"> 1. Empty dust cup filter (see page 6). 2. Turn unit off and unplug from wall outlet. Remove Dust Cup Filter and check for object(s) in air duct and remove. 3. Clean or replace Dust Cup Filter (see page 6).
DUST ESCAPING FROM HAND VACUUM	<ol style="list-style-type: none"> 1. Dust Cup Filter is full. 2. Dust Cup Filter is not installed correctly. 3. Puncture/hole in Dust Cup Filter. 	<ol style="list-style-type: none"> 1. Empty Dust Cup Filter. 2. Review Dust Cup Filter instruction (see page 6). 3. Replace dust Cup Filter (see page 6)
HAND VACUUM HOSE OR BRUSHES WILL NOT PICK-UP	<ol style="list-style-type: none"> 1. Hose clogged. 2. Dust Cup Filter is full. 	<ol style="list-style-type: none"> 1. Remove hose and/or brushes. 2. Remove obstruction from hose. 3. Empty and clean Dust Cup Filter.

SERVICE FOR YOUR VACUUM

Your best source for service or to purchase additional accessories is the authorized dealer where you purchased your handvac.

You may also order parts and accessories by writing or calling us, advising what you need, the model number of your vacuum, your return address and phone number(s), and when you can be reached. Contact us at:

Sunbeam genuine parts and service: 1-866-933-0427

ORIGINS INTERNATIONAL LIMITED

3337 Kraft Avenue S.E.
Grand Rapids, MI 49512

YOUR PRODUCT WARRANTY	Staple your sales receipt here. Proof of original purchase date is needed to obtain service under warranty.
------------------------------	--

LIMITED WARRANTY

For one year from the date of purchase by the original owner, ORIGINS will, at its option, repair or replace any part of the appliance, which proves to be defective in material or workmanship under normal use. During this period, ORIGINS will provide all parts necessary to correct any such defect free of charge, as long as the appliance has been operated in accordance with the written instructions in this manual. In rental or commercial use, the warranty period is 90 days. All products requiring service must be brought/sent to an authorized service center or to ORIGINS for repair.

WHAT TO DO IF YOU HAVE PROBLEMS: Should your vacuum prove defective during the warranty period, please return to the authorized dealer where the vacuum was purchased. ORIGINS will, at its option, replace on an exchange basis the defective part(s), at no charge except inbound freight.

WHAT IS NOT COVERED

This warranty covers only normal consumer use. This warranty does not cover bags, belts, lamps, agitator brush, roller brushes, motor carbon brushes, filters and any third party parts, components or other parts added to the vacuum cleaner after its shipment from ORIGINS. ORIGINS is not responsible for warranty service should the vacuum cleaner's label, logo, rating label or serial number be removed, or should the product fail to be properly maintained or fail to function properly as a result of misuse, abuse, improper operation, neglect, improper shipping, damage caused by disasters such as fire, flood, and lightning, improper electrical current, commercial use, or service other than by an authorized servicer. Packaging and shipping cost incurred in presenting your Sunbeam® vacuum product for warranty service are your responsibility. If a claimed defect cannot be identified or reproduced in service, you will be held responsible for costs incurred.

THE WARRANTY PROVIDED ABOVE IS EXCLUSIVE AND IN LIEU OF ALL OTHER EXPRESS OR IMPLIED WARRANTIES INCLUDING, BUT NOT LIMITED TO THE IMPLIED WARRANTIES OF MERCHANTABILITY OR FITNESS FOR A PARTICULAR PURPOSE. SOME LAWS DO NOT ALLOW THE EXCLUSION OF IMPLIED WARRANTIES. IF THESE LAWS APPLY, THEN ALL EXPRESS AND IMPLIED WARRANTIES ARE LIMITED TO THE WARRANTY PERIOD IDENTIFIED ABOVE. UNLESS STATED HEREIN, ANY STATEMENTS OR REPRESENTATIONS MADE BY ANY OTHER PERSON OR FIRM ARE VOID. EXCEPT AS PROVIDED IN THIS WRITTEN WARRANTY, NEITHER ORIGINS NOR ITS AFFILIATES SHALL BE LIABLE FOR ANY LOSS, INCONVENIENCE OR DAMAGE INCLUDING DIRECT, SPECIAL, INCIDENTAL OR CONSEQUENTIAL DAMAGES, RESULTING FROM THE USE OR INABILITY TO USE THE VACUUM PRODUCT, WHETHER RESULTING FROM BREACH OF WARRANTY OR ANY OTHER LEGAL THEORY. IN NO EVENT WILL ORIGINS'S LIABILITY EXCEED THE PURCHASE PRICE OF THE VACUUM CLEANER.

Some jurisdictions do not allow limitations on how long an implied warranty lasts and some jurisdictions do not allow the exclusion or limitation of incidental or consequential damages, so the above limitations and exclusions may not apply to you. This warranty gives you specific legal rights, and you may also have other rights, which vary from jurisdiction to jurisdiction.

Sunbeam genuine parts and service: 1-866-933-0427

Sunbeam® is a registered trademark of Sunbeam Products, Inc. used under license. Distributed by Origins International Limited, 3337 Kraft Avenue SE, Grand Rapids, MI 49512